



GAFIM

Surface-mounted watertight projector for discharge lamp

White powder-coated steel body
Integrated and compensated gear
Safety glass secured by screws
with watertight silicone seal
Internal symmetrical shiny aluminium reflector

Options:

- RAL 7001 grey body
- Protective grid (GD)
- Backup equipment (SEC): relay with 150 W halogen source for use in case of power micro-cuts (only 250W)
- Asymmetrical reflector (ASYM)

Projecteur apparent étanche pour lampe à décharge

Corps en acier poudré blanc
Appareillage intégré et compensé
Vitrage de sécurité fixé par vis
avec joint d'étanchéité silicone
Réflecteur interne symétrique en aluminium grand brillant

Options :

- Corps teinté gris RAL 7001
- Grille de protection (GD)
- Équipement secours (SEC) : relais avec une source 150 W halogène en cas de microcoupures (sur la version 250W uniquement)
- Réflecteur asymétrique (ASYM)

IP65
Classe 1
850 °C
IK08

Référence	Puissance (W)	Source / culot	LxH (mm)	Rendement	Poids
Reference	Power (W)	Source / Base socket	LxH (mm)	Efficiency	Height
GAFIM 150 MIH	150	MH / E40	550 x 360 x 191	0.67 C	12.6 Kg
GAFIM 250 MIH	250	MH / E40	550 x 360 x 191	0.76 C	13.1 Kg
GAFIM 250 MIH SEC	250 + 150 W	MH / E40 – HAL/E27	550 x 360 x 191	0.76 C	13.5 Kg
GAFIM 400 MIH	400	MH / E40	550 x 360 x 191	0.85 C	14Kg
GAFIM 250 SN	250	SN / E40	550 x 360 x 191	0.76 C	13.1 Kg
GAFIM 250 SN SEC	250 + 150W	MH / E40 – HAL/E27	550 x 360 x 191	0.76 C	13.5 Kg
GAFIM 400 SN	400	SN / E40	550 x 360 x 191	0.85 C	14Kg

ZI de Ladoux
Rue Verte
63118 Cébazat
France

Tél. 33 (0)4 73 25 84 00

Fax 33 (0)4 73 24 80 00

sunlux.eclairage@sunlux.fr

www.sunlux.fr

SA au capital de 450 000 €

N° SIREN 333 074 383

Code APE 2740 Z

N° TVA intracommunautaire

FR 68 333 074 383

Existe en version SECOURS
(250w Uniquement)



Vitrage maintenu
par filin pour
maintenance
Glass held by ties
for maintenance

Existe en version
encastrable GEFIM





GAFIM

**Projecteur apparent étanche
pour lampe à décharge**
**Surface-mounted watertight
projector for discharge lamp**

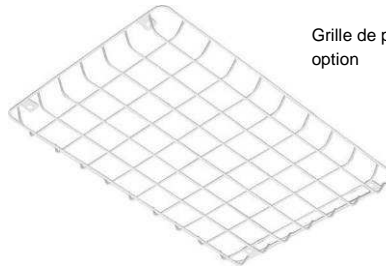

Grille de protection en option



GAFIM 150 MIH

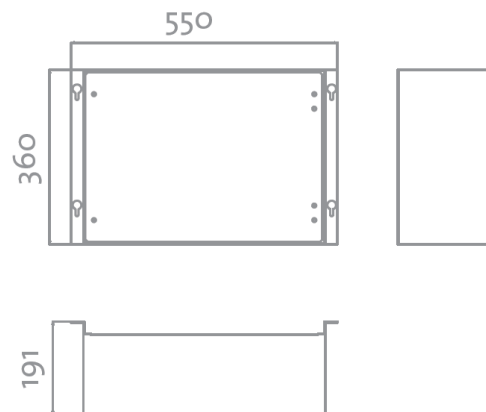
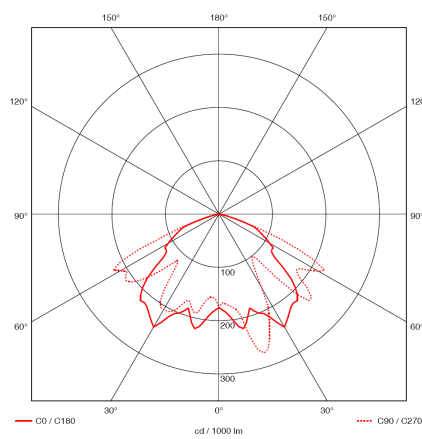

GAFIM 250 MIH

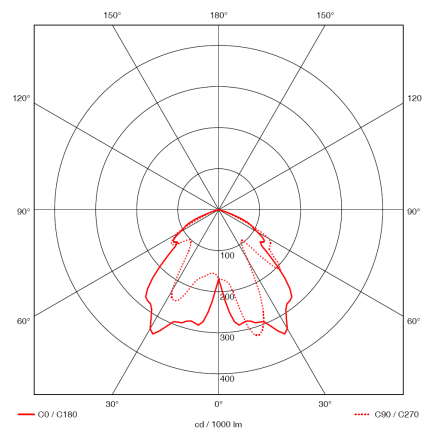

GAFIM 400 MIH

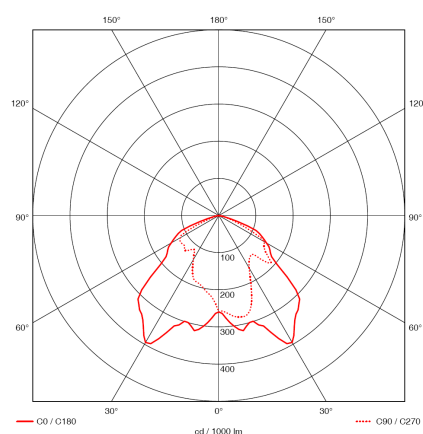

ZI de Ladoux
Rue Verte
63118 Cébazat
France

Tél. 33 (0)4 73 25 84 00
Fax 33 (0)4 73 24 80 00
sunlux.eclairage@sunlux.fr
www.sunlux.fr

SA au capital de 450 000 €
N° SIREN 333 074 383
Code APE 2740 Z
N° TVA intracommunautaire
FR 68 333 074 383



Informations :
Bureau Etudes
04 73 25 84 00
data@sunlux.fr